

# OSLoop Control System

## Technical Information & Operating Instructions



### Introduction

The SE Controls OSLoop range of control systems includes a built, tested and EN12101-10 certified control panel designed for smoke ventilation systems and for use with SE Controls supplied equipment. They must not be used for any other application or in conjunction with other manufacturers' products without prior consultation with SE Controls.

Installation of this equipment must only be carried out by competent and qualified persons.

The Installer and end user are requested to read, understand and retain this information pack with the panel for future reference.

This document must be retained for future reference by the client and be made available for reference by persons installing, servicing or modifying the panel.

### Application

OSLoop is a modular smoke control system. It consists of a centralised coordination module (the coordinator) and between 1 and 16 remotely mounted manual control points (MCPs). Larger systems can be constructed by linking together multiple coordinators.

The coordinator controls power and data to the networked system fully monitoring primary (mains) and secondary (battery\*) power supplies. The OSLoop system intelligently monitors current requirements of the system and determines how and when the MCPs can call on this power to activate AOVs.

\*Batteries sold separately

# Contents

## 1. General Information

1.1.	General Safety Information	4
1.2.	Health and Safety	4
1.3.	Environment	4
1.4.	User Responsibilities	4
1.5.	Maintenance	5
1.6.	Installation and Connection	5
1.7.	Fault Finding	5
1.8.	Contact Information	5
1.9.	Certification	5

## 2. Specification

2.1.	Device Overview	6
2.2.	Manual Control Points (MCP)	7
2.3.	External Indication	7
2.4	Smoke Detector	7
2.5	Back Up Battery	7
2.6	Activation Keys	7
2.4.	Volt Free Relay indication	8
2.5.	Recommended Cable Types	8

## 3. Installation and Commissioning

3.1.	Pre-Installation	9
3.2.	Mounting :Location	9
3.3.	Fixing	9
3.4.	Coordinator Connection Detail	9
3.5.	Loop In/Loop Out	10
3.6.	OSLoop Connection at the MCP	10
3.7.	Smoke Detector to MCP Wiring	11
3.8.	Fire Alarm Connection	12
3.9.	Actuator Connection	13
3.10.	Actuator Mode Jumper	14-15
3.11.	Set Jumpers on the Coordinator	14-15
3.12.	OSLoop Loop Continuity Check	14-15
3.13.	Option: OSLink Connections	15
3.14.	Option: Relay Output to OS2 Stairwell and Shared Stairwell Connections	16

3.15.	Repeater Panel Connections	16
3.16.	MCP Zone Switch	17
3.17.	Single Floor Activation Interlock	17
3.18.	Dip Switches	18
3.19.	Top/Bottom Stairwell	18
3.20.	Fitting of MCPs	19
3.21.	Operation of the MCP CoverFlap	19
3.22.	Mains Power Supply	20

## 4. Fault Codes

4.1.	Coordinator Flash Codes	21-22
4.2.	MCP Plash Codes	22-23

## Important Notices

- The equipment has no mains on/off switch and is intended for permanent connection only.
- Do NOT allow abuse or mishandling of the device.
- Do NOT adjust or alter the device or its enclosure including labelling/markings.
- Do NOT use this controller for any other purpose other than that intended by the manufacturer.
- Do NOT allow installation of this equipment by persons not electrically qualified.
- Damage to the equipment due to failure to test the electrical integrity of external wiring will invalidate any warranties.
- Failure to install the device in accordance with the manufacturer's instructions will invalidate any warranties.
- Failure to follow current electrical regulations governing the installation of fixed equipment can lead to prosecution and may invalidate any warranties.
- Unless otherwise indicated, you must not adjust or remove existing manufacturers cabling or use terminal outputs or inputs for purposes other than their design without written authorization from SE Controls.
- Consumable items e.g. fuses & batteries where replacement is needed must be replaced with parts of equivalent manufacturing standard/compliance and rating.

**SE Controls accepts no liability for failure to comply with these statements or the installation and operation guidance in the following sections of this guide and reserves the right to invalidate the warranty of the controller**

**SE Controls reserves the right to introduce any modifications and improvements to the contents of this publication without the obligation of giving prior notice.**

# 1. General Information

## 1.1. General Safety Information



Read and observe the information contained in these instructions.

Please keep these safety instructions for future reference and maintenance. Reliable operation and the prevention of damage and risks are only granted if the equipment is assembled carefully and the settings are carried out according to these instructions and to the operating instructions of the drives.

Please observe the exact terminal assignment, the minimum and maximum power ratings (see technical data) and the installation instructions.

## 1.2. Health and Safety



**Electrical Safety:** Warning 230 V ac mains supply can cause death, serious injury or considerable material damage. Disconnect the equipment from the power supply at all poles before opening, assembling or carrying out any work.

**Electrical safety of batteries:** Short circuiting of the lead acid batteries can cause high currents to flow which can cause rapid heating and a fire risk. Take care to avoid this when transporting and handling batteries. Keep batteries disconnected during installation and modification of the installation.

**Competence:** This equipment is designed for professional installation only by qualified, trained and safety conscious electricians or skilled and trained staff with considerable knowledge of electrical equipment installation. These instructions must be followed and retained for future reference.

**Application:** This equipment is designed exclusively for the purposes of controlling automatically opening smoke ventilation equipment.



**Personal Protective Equipment:** It is recommended that suitable PPE is worn at all times during the installation and connection of actuator products in accordance with a recommended safe system of work.



**Handling and storage:** This equipment is heavy. Care must be taken in transportation to the installation location and during fitting. The equipment must not be dropped, impacted, allowed to get wet or abused in any other way. Mishandling can result in serious damage to the housing and the components therein.



**Risk of crushing:** this equipment can automatically close windows and other appliances without warning. Beware risk of serious injury from crushing of hands or fingers.

## 1.3. Environment



This equipment is fitted with a pair of lead acid batteries which contain a corrosive gel. These batteries must be regularly inspected for damage and condition. Lead acid batteries are classified as hazardous waste and must be disposed of by an authorised and licensed recycler. They must not be disposed of in household waste or 'general waste' skips.



Redundant electronic products are classified as hazardous waste under the WEEE regulations (Waste Electrical and Electronic Equipment). Electronic parts must be disposed of by an authorised and licensed recycler. They must not be disposed of in household waste or 'general waste' skips.

If recycling facilities are not locally available, contact SE Controls who can arrange for recycling and disposal of old electronic products.

## 1.4. User Responsibilities

### United Kingdom Only:

BS 7346-8:2013 is a British Standard code of practice for the planning, design, installation, commissioning and maintenance of smoke control systems. Section 9 of the standard (Maintenance and Servicing) states that frequent inspection of the system should be undertaken by a named suitably-trained member of the premises management team.

Routine inspection of the system should be carried out in accordance with BS 9999:2008, Annex V.

### For countries outside the United Kingdom:

Please check with the local fire authority in your area regarding smoke control legislation, different user responsibilities may apply.

**Smoke control equipment should only be maintained by a competent person with specialist knowledge of smoke control systems and sufficient information regarding the system.**

## 1.5. Maintenance



An smoke control system should be checked and serviced periodically in accordance to local smoke control legislation.

Smoke control systems have to be serviced and checked for defects at least once per year by an authorised, trained and competent person.

**Within the UK a suitable service contract with SE Controls is recommended for this purpose, (see section 1.8 for contact information).**

All batteries need to be checked to see if they are within specification and in good condition at least once a year and replaced at least every **THREE YEARS** (please observe the battery commissioning label).



Ensure that supply voltage and batteries are disconnected before any maintenance work or mechanical/electrical alterations are made.

**The system must be protected against unintentional start-up!**

After maintenance, modification or repair the system must be functionally retested.

Compatibility; this equipment should only be used to operate with motors and other products approved by SE Controls. No liability will be accepted and neither guarantee nor service is provided if unapproved products are used in conjunction with this equipment.

## 1.6. Installation and Connection



Installation should be carried out by an authorised, trained and competent electrician.

Ensure correct cable type is used throughout the installation. All low voltage cables are to be routed separately from mains voltage cables and other electrically noisy cables. Flexible cables must not be plastered over and freely suspended cables must be provided with strain relief. Cables must be installed in such a way that they cannot be sheared, twisted, pierced or otherwise damaged during installation or use. Junction boxes should be accessible for inspection and maintenance.

**Do not attempt to install or alter the installation of the panel whilst connected to the power supply.**

## 1.7. Fault Finding



In the unlikely event that a problem occurs with the control panel, users are urged to contact SE Controls for assistance.

If the system operates from mains power but when mains power is removed will not operate from batteries, it is possible that the batteries will require replacement.

There are no user repairable parts. Fault rectification must only be carried out by authorised and competent persons.

## 1.8. Contact Information

**For sales, technical support and maintenance please contact:**

SE Controls  
Lancaster House  
Wellington Crescent  
Fradley Park  
Lichfield  
Staffordshire  
WS13 8RZ

**Tel:** 01543 443060

**Fax:** 01543 443070

**Website:** [www.secontrols.com](http://www.secontrols.com)

## 1.9. Certification

SE Controls hereby certify that the parts and services detailed hereon have been manufactured, inspected, tested and supplied in accordance with the conditions and requirements of the procedures as documented in the Company Quality Assurance System to ensure conformance with SE Controls' specifications, and with the contract or order conditions of our BS EN ISO9001:2015 registration.



Our equipment is built and tested in accordance with the requirements of EN12101-10:2005/AC:2007. Certification may be provided on request.

## 2. Specification

### 2.1. Device Overview

<b>Part Number</b>	FCS00300010
<b>Dimensions</b>	310 x 380 x 130mm (W x D x H)
<b>Mass Approx.</b>	4.1kg
<b>Supply</b>	230V ac 50/60Hz. (±10%) from a 5A unswitched spur
<b>Power Consumption</b>	Max. 500VA
<b>Typical Output Voltage (mains power)</b>	Typical Output Voltage (mains power, max load 7.0A) Nominal 24.0 V Max. 28.4V at 253V ac Min. 19.2V at 207V ac
<b>Typical Output Voltage (no main)</b>	Nominal 24.0V Max. 28.8V Min. 18.5V
<b>*Maximum Current (mains and batteries)</b>	Max 7.0A for 180 seconds Peak current can exceed 7.0A for a short duration
<b>*Auxiliary Outputs</b>	VC, VD, VE, Nominal 24.0 V, 100mA / 40mA
<b>Battery Backup</b>	2 x 12V dc 12.0Ah sealed lead-acid (not included)
<b>Expected Battery Life</b>	3 Years @ 25°C
<b>Real Time Clock Battery Life</b>	10 Years
<b>Cable Entries</b>	Cable entries are via up to 6 off 20mm end mounted cable glands and/or one rear entry slot for concealed connection
<b>IP Rating</b>	IP30
<b>Humidity Range</b>	10 to 90% Non-condensing
<b>Storage</b>	-20°C to +50°C
<b>Operating Temperature</b>	--5°C to +40 °C
<b>*Battery Standby Time</b>	72 Hours

\*On mains failure, average auxiliary current must be less than 20mA to achieve 72 Hours BBU.

## 2.2. Manual Control Point (MCP)

<b>Part Number (Standard MCP)</b>	FCS00300017 (Module Assembly) FCS00300018 (Adapter Plate Assembly) FCS00200080 (Module & Adaptor Plate Assembly)
<b>Part Number (Tamper Proof MCP)</b>	FCS00300020 (Module Assembly) FCS00300018 (Adapter Plate Assembly) FCS00200081 (Module & Adaptor Plate Assembly)
<b>Dimensions</b>	87 x 87 x 50mm (H x W x D Approx.)
<b>Mass Approx</b>	0.1 KG
<b>Supply</b>	20V-29V
<b>Typical Output Voltage</b>	Nominal 24.0V Max. 28.8V Min. 18.5V
<b>Maximum Current</b>	Max 3.0A for 180 seconds Peak current can exceed 3.0A for a short duration
<b>IP Rating</b>	IP20
<b>Humidity Range</b>	10 to 90% Non-Condensing
<b>Storage</b>	- 20°C to 75°C

## 2.3. External Indication

Lamp	Detail
Fault	Flashes when a fault is present (see fault codes)
Fault Condition	Lit when the controller is activated by a fire input or via a MCP open signal
Standby	Lit when healthy and mains supply is connected.

**Note: The functions of the LEDs reflect active and healthy relays. The function of these relay can be modified by parameter changes.**

## 2.4. Smoke Detector

<b>Part Number</b>	ADA55000318 (Smoke Detector Head)
<b>Part Number</b>	ADA45681200 (Smoke Detector Base)

## 2.5. Back Up Battery

<b>Part Number</b>	ABB00660016 (12 Volt 12 AH Back Up Battery)*
--------------------	--

\*x2 Batteries required

## 2.6. Reset/Activation Keys

<b>Part Number</b>	FCS00200024 (MCP Dumb Reset Key)
<b>Part Number</b>	FCS00200033 (Activation Key - Open Only)

## 2.7. Volt Free Relay Indication

Terminal	Description
(Activated) CM	Activated relay common
(Activated) NC	Activated relay normally closed (opens when activated)
(Activated) NO	Activated relay normally open (closes when activated)
(Activated) LP	Do not use!
(Healthy) CM	Healthy relay common
(Healthy) NC	Healthy relay normally closed (opens when healthy)
(Healthy) NO	Healthy relay normally open (closes when healthy)
(Healthy) LP	Do not use!

## 2.8. Required Cable Types

Cabling For	Minimum Number of Cores	Required Cable Type
<b>Mains Supply Cable</b>	2 Core + Earth x 1.5mm <sup>2</sup>	FP Plus or equivalent
<b>OSLoop MCP</b>	4 Core + Earth x 2.5mm <sup>2</sup>	FP Plus or equivalent
<b>24V dc Actuator</b>	2 Core + Earth x 1.5mm <sup>2</sup>	FP Plus or equivalent
<b>OSLoop Smoke Detector</b>	2 Core + Earth x 1.5mm <sup>2</sup>	FP Plus or equivalent
<b>OSlink Network Cable</b>	2 Core + Earth x 1.5mm <sup>2</sup>	FP Plus or equivalent
<b>SHEVTEC Repeater Panel</b>	4 Core + Earth x 1.5mm <sup>2</sup>	FP Plus or equivalent

All cabling should be in accordance with relevant standards and regulations for electrical installation such as BS7671.



# 3. Installation and Commissioning

## 3.1. Pre-Installation

After unpacking the controller, use a 3mm hex key to unfasten each of the ¼ turn catches and allow removal of the lid of the control unit. It is recommended that the lid be temporarily placed back inside the packaging to prevent damage to the paint finish.

**Note:** The Coordinator 12Ahr sealed lead acid batteries are shipped separately from the factory, due to their weight.

## 3.2. Mounting Location

The coordinator is environmentally rated at IP20 and hence should not be located where exposure to damp/moisture or significant amounts of dust is likely. In particular, do not mount the controller in extreme environments such as cold rooms/ovens and those areas classified as having potentially explosive atmospheres.

Mount the coordinator on a level secure surface. Ensure that when correctly fixed, the surface can support the weight of the controller. The controller can be mounted on any vertical surface such as a wall.

Typically, the OSLoop system is installed as a smoke shaft controller and consequently a good mounting point for the coordinator is at the top or bottom of the building, within the electrical riser.

## 3.3. Fixing

Hold the body of the coordinator up against the surface to which it is to be fixed. Ensure that it is mounted at least 50mm above the floor level to reduce the possibility of water damage.

Mark through the three keyed fixing holes with a marker pen and place the coordinator body to one side. Drill appropriately sized pilot/fixing holes and use suitable plastic plugs/cavity fixings where appropriate. Note that it is recommended that 40mm No8 pan head screws are used to secure the body in place.

Fit the three screws into place leaving about 5mm protruding from the wall. Offer up the coordinator body to these screws and ensure that all three key-ways are fully engaged. Fully tighten the screws so that the coordinator body is fixed firmly into place.

It is recommended that the required number of cable entry glands is now assessed. A combination of 6 knock-outs and fully open gland holes are provided for this purpose. In the unlikely event of the final system requiring more than this, use a 20mm hole cutter as required. Do not allow metal swarf to enter the coordinator body.

## 3.4. Coordinator Connection Detail

Except for the 230V ac incoming power supply, all the field wiring connections are grouped logically on the top edge of the main PCB (see figure below).

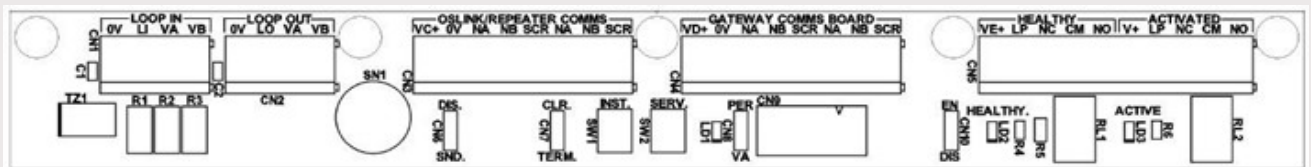

Note: that all terminals are suitable for solid cable with a maximum cross-sectional area of 2.5mm<sup>2</sup>. Also note that all field wiring connections are accessible with the Perspex protective cover still in place.

### 3.5. Loop In/Loop Out

The main OSLoop cables are connect to/from the coordinator as follows

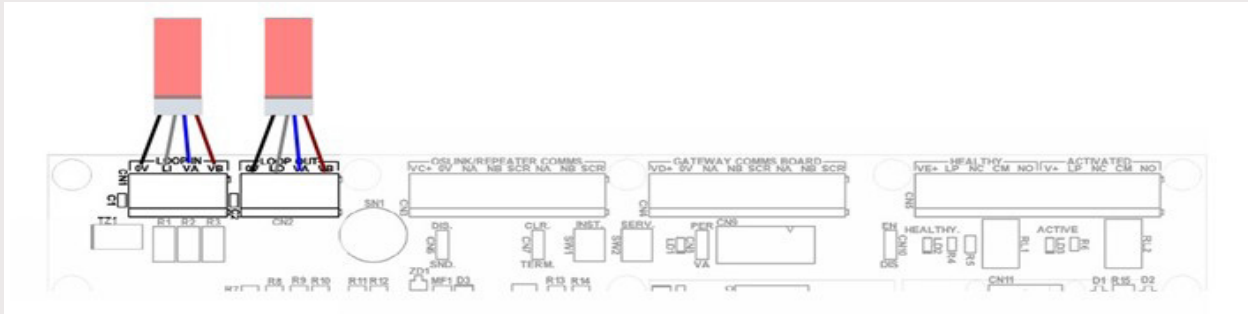

Ensure a consistent colour scheme is used all around the loop

There is no need to identify the incoming and outgoing cables as the MCP will function equally well with the in and out connections swapped.

### 3.6. OSLoop Connection at the MCP

The main OSLoop cables connect coordinator to MCP and MCP to MCP as follows:

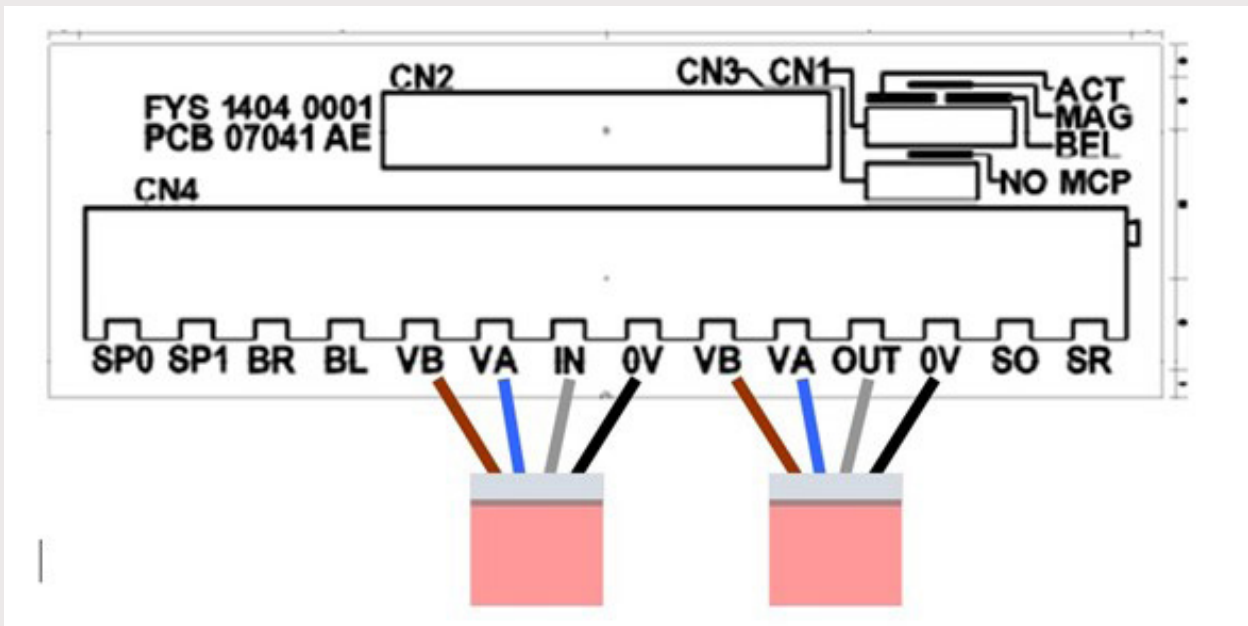

Ensure a consistent colour scheme is used all around the loop

There is no need to identify the incoming and outgoing cables as the MCP will function equally well with the in and out connections swapped.

\*The cable outer screen is left unconnected

### 3.7. Smoke Detector to MCP Wiring

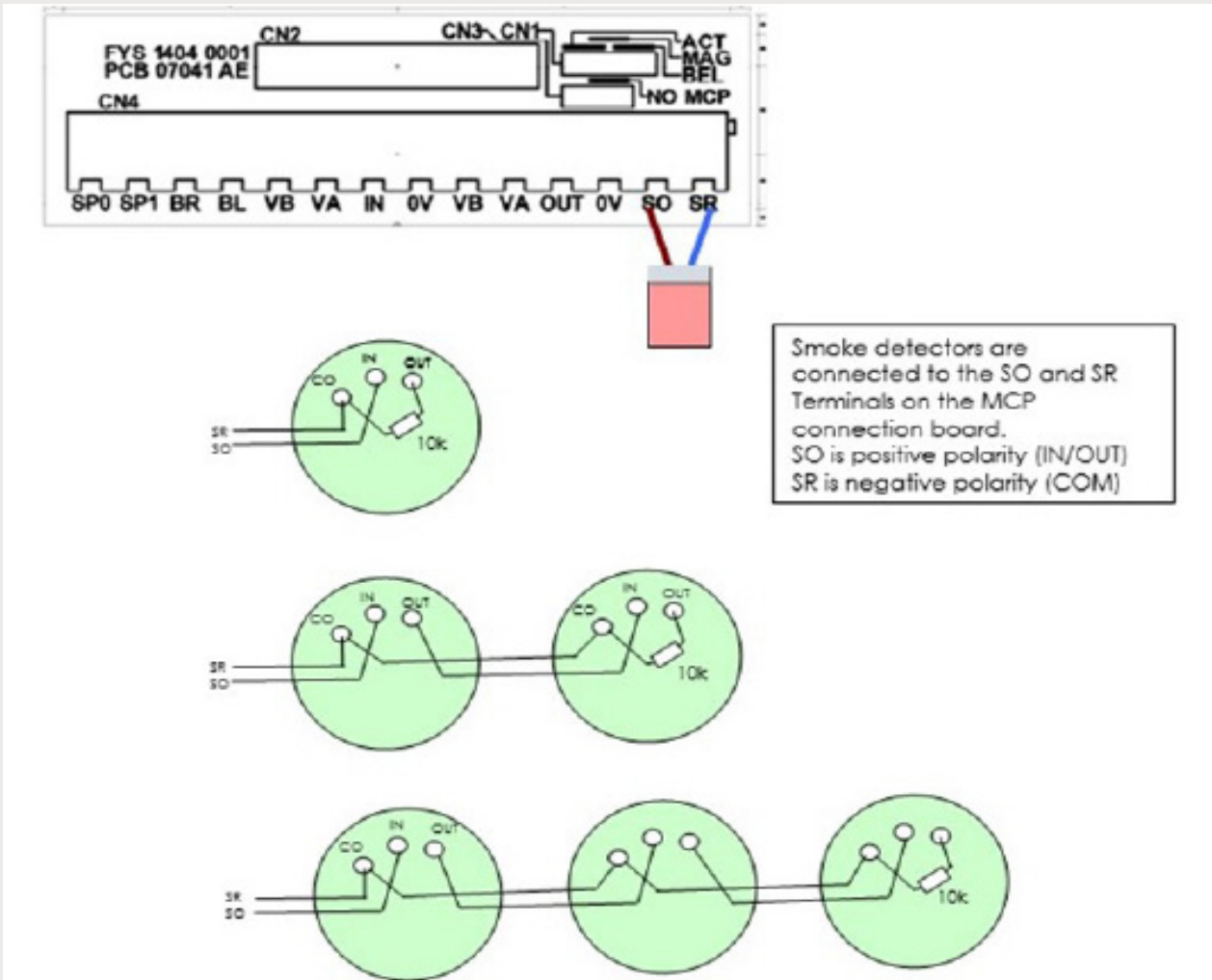

The illustration above shows S.E.Controls preferred timesaver bases - Connection to other makes of smoke detectors will be similar.

For end of line monitoring to function properly, the smoke detector bases must be wired in series, where the end of line resistor is wired to the last smoke detector base as shown above. Removal of the smoke head will break the connection from IN to OUT, and an alarm raised. Smoke detector bases should not be of the type with a diode between IN and OUT.

Any cable shield is left unconnected. For smoke detectors, use terminator resistors FCS 0030 1001.

### 3.8. Fire Alarm Connection

Where the system is activated by fire alarm interface, the SO and SR terminals are connected to the interface via an ACG 5000 1595 contact monitoring module.

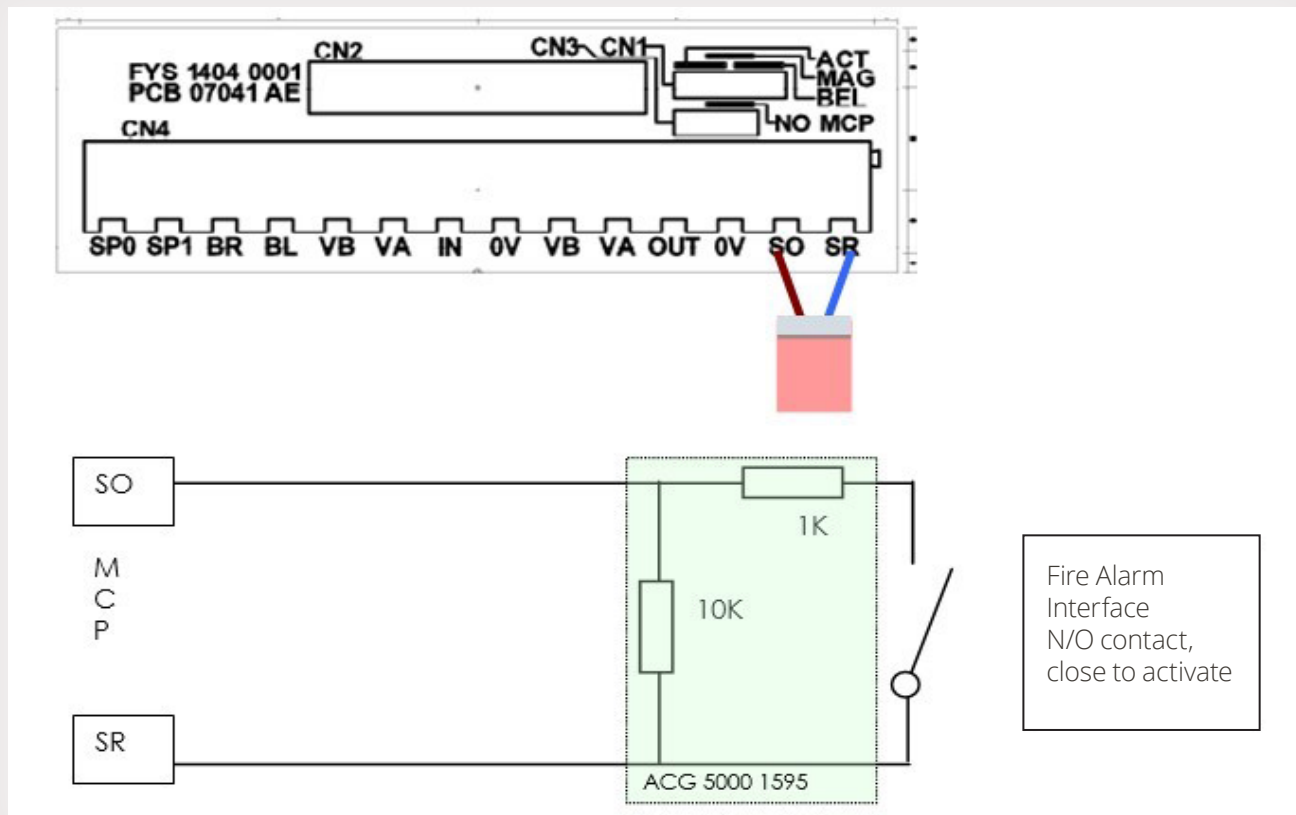

The contact monitoring module should be installed as close to the fire alarm interface as possible (commonly inside the same enclosure), to allow monitoring of the full length of the cable to the MCP.

This connection is not polarity sensitive. Any cable screen is left unconnected.

### 3.9. Actuator Connection

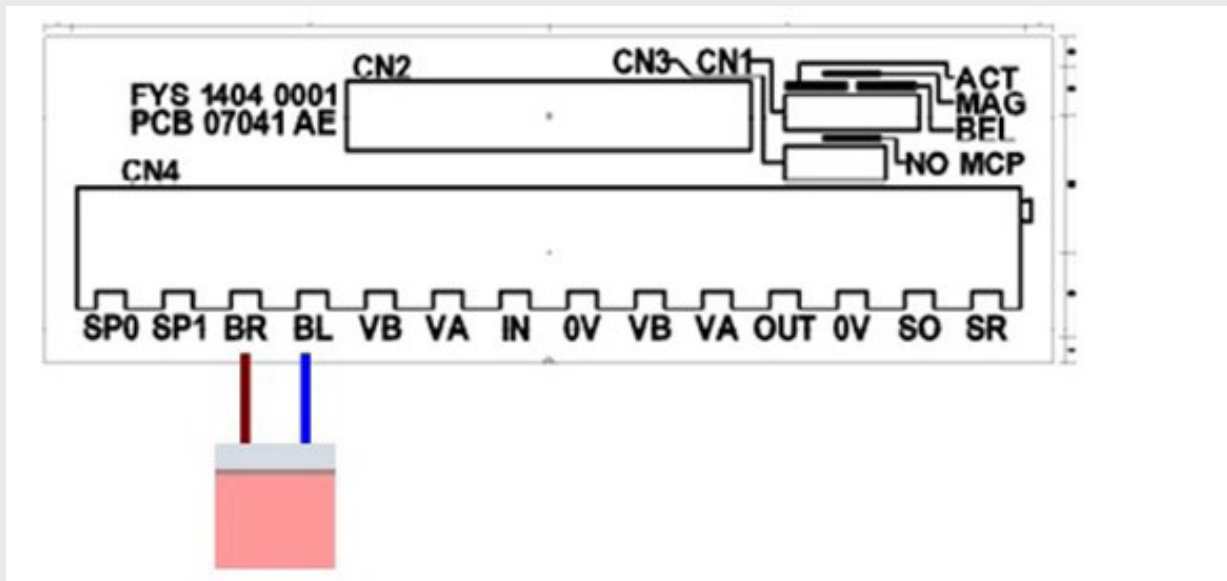

The actuators are connected to the BR and BL terminals on the MCP connection board.

If connection is via a junction box within the smoke shaft, a high temperature rated ceramic terminal block is preferred.

Some actuators require a 1k terminating resistor which if needed, should be fitted close to the actuator. Other actuators have inbuilt resistors or similar circuitry, and do not require a resistor to be fitted. Refer to the below table full compatibility matrix.

Any cable screen is left unconnected.

### 3.10. Actuator Mode Jumper

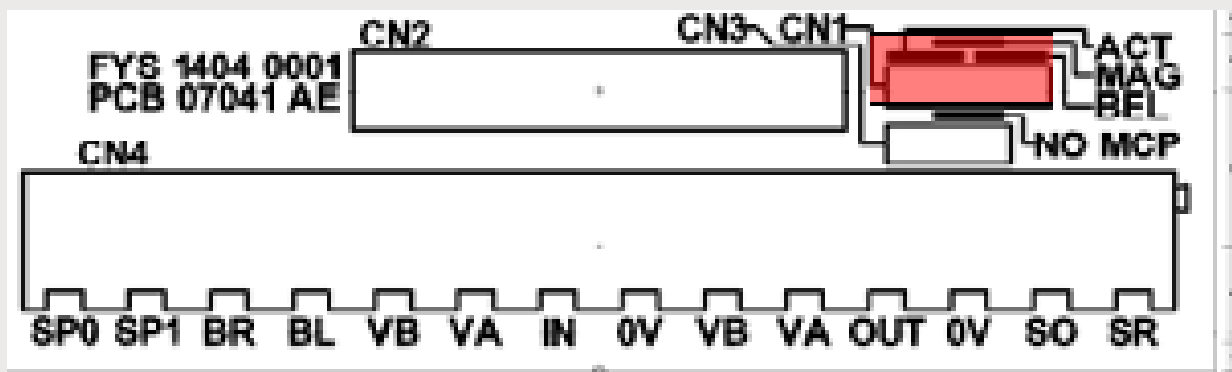

The actuators mode jumper on each connection board must be set at every MCP to match the type of actuator. This jumper has 3 positions.

Jumper Position	Jumper Position 1 (ACT)	Jumper Position 2 (MAG)	Jumper Position 3 (BEL)
Operating Mode	Actuator unpowered in standby, pulses every 20 seconds to test end-of-line	Permanent 24V until activated	Permanent 24V to actuator unless mains fails.
Use With	Actuators with position sensing limit switches only	Magnetic catch.	Most other actuators with current sensing limit switches and louvre actuators. (e.g. SECO Ni 24 40 AASTxxxxxx)

### 3.11. Set Jumpers on the Coordinator

The default position of jumpers is as follows:

CN6 enables the sounder on the coordinator

CN8 disables OSlink terminator resistor – do not enable

CN10 enables the relay outputs – may be disabled to give extra power saving.

### 3.12. OSLoop Continuity Check

It is recommended that this check is performed after wiring all the MCP connection boards, but before connecting the OSLoop cables at the coordinator:

Set the jumper on every MCP connection board to 'No-MCP' (right). This connects IN and OUT terminals

Do not refit the MCPs to any connection board.

### 3.12. OSLoop Continuity Check, (cont.)

Using a multi-meter set to measure ohms; check the continuity of each wire in turn (VA, VB, in/out, 0V) from the outgoing cable to the return cable. Typical 2.5mm<sup>2</sup> cables have a resistance of 7.4ohms per kilo-meter, so the expected resistance loop resistance should be less than two ohms.

Also check for high resistance (>100kohm) from every conductor to every different one.

This test detects most loop wiring faults, but cannot detect when a connection has been swapped and swapped back.

### 3.13. Option: OSLink Connections

On some systems, the OSLink/Repeater connector is used to communicate with repeater panels or to other OSLoop coordinators. Connections NA and NB are duplicated to allow two cable connections.

Terminals			
OSLoop	OS2	Repeater Panel	Cable Colours
NA	NTA	NTA	Blue
NB	NTB	NTB	Brown
VG+	-	V+	Black
OV	SCR	OV	Grey

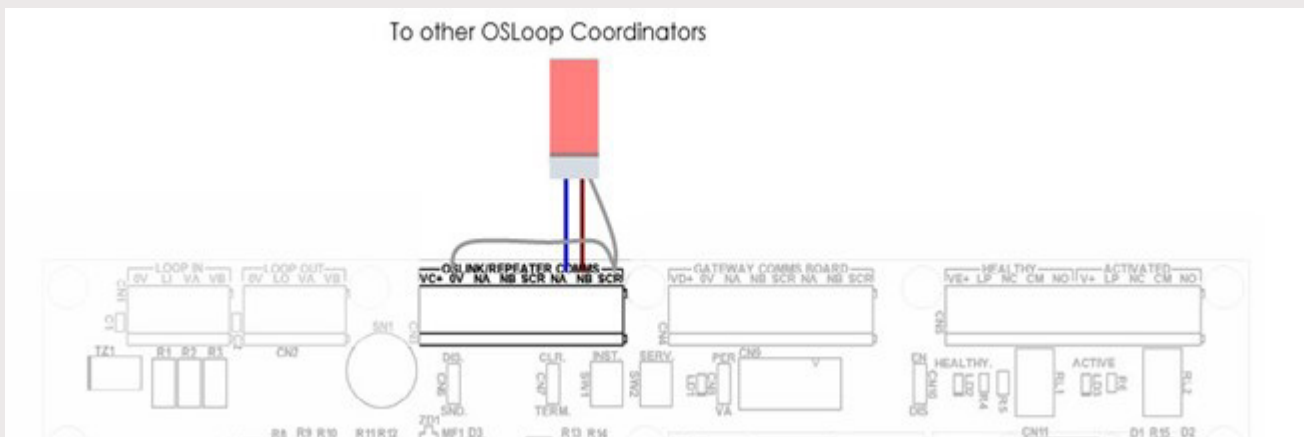

Coordinator to coordinator connections do not require power, and may be wired in two core plus earth. In this case, connect the protective screen to 0V at both ends.

### 3.14. Option: Relay Output to OS2 Stairwell and Shared Stairwell Connections

The OSLoop activation relay allows triggering of stairwells controlled by OS2s.

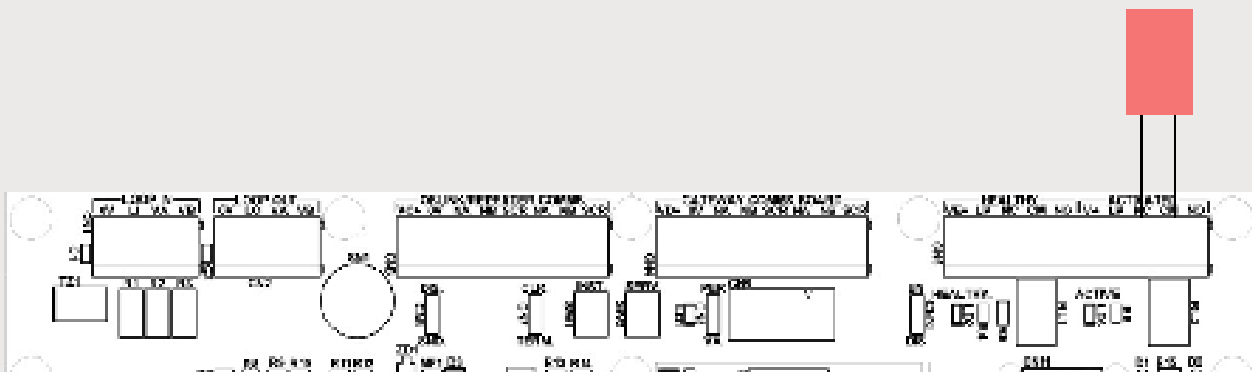

Where more than one smoke stack triggers a common stairwell, it is possible to wire the active relays NC contact from several coordinators in series, and use this signal to trigger an OS2 type controller.

### 3.15. Repeater Panel Connections

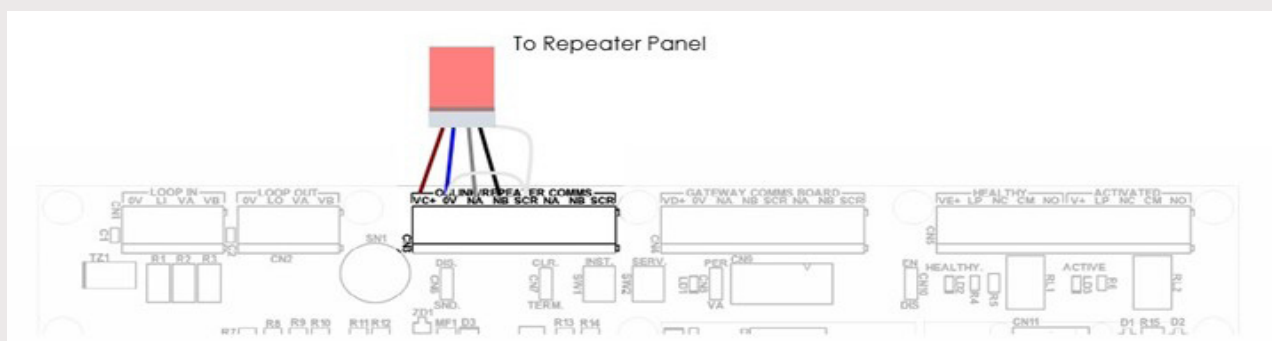

The repeater panel uses a four-way connection to carry data and power.

Four-way cables should have the protective screen linked to 0V at one end only. Where the cable construction is two twisted pairs, the data and power should be carried on separate pairs.



### 3.16. MCP Zone Switch

The zone switch is a rotary dipswitch allowing the MCP zone to be set from 0 to 15 (labelled 0 to F on switch).

For a typical simple smoke vent installation, each zone switch is set to a unique value, preferably but not necessarily to the same as the floor number of the building.

From coordinator software 1.1 onwards: Zones 0-12 are now pre-configured as single smoke detector group. Any smoke detector active input in this group will inhibit smoke detector in all others in the group. This prevents more than one vent opening due to stray smoke. Use zones 0-12 for smoke shaft vents only, or modify both parameters [ZSSD] and [ZSZI] to change the single smoke detector group. Do not install stairwell or independent AOV controls within this group as their activation could prevent stack operation.

Two or more MCPs may be 'ganged' by setting them to the same zone. Ganged MCPs are all activated if any input on any MCP in that zone activates. MCPs in the same zone will close together provided parameter [ZCLS] is set (default=set), or must be closed separately if clear.

'Top of stack' and 'top of stairwell' should be set to different zones, and zone 15 is preferred for the stairwell.

### 3.17. Single Floor Activation Interlock

Zones 0-12 are now pre-configured as single floor activation group. Any smoke detector active input or MCP red button activation in this group will inhibit smoke detector and red buttons in all others in the group. This prevents more than one vent opening due to stray smoke. Zones 0-12 should be used for smoke shaft vents only, or modify the parameters [ZSSD], [ZSZI] and [ZSIB] to change the single floor group (normally all the same value)

**Parameter [ZSSD]** controls the zones which when active will start the single floor interlock.

**Parameter [ZSSI]** controls the zones which have the SD/FA input disabled by an activation in [ZSSD].

**Parameter [ZSIB]** defines the zones which have the red button disabled by an activation in [ZSSD].

Do not install stairwell or independent AOV controls within the [ZSSD] group as their activation could prevent stack operation.

### 3.18. Dip Switches

There are four dipswitches on the rear of the MCP.

#### **Switch 1 Auto-reset - Default position = off**

The MCP is normally configured so the reset button must be held to close the vent, i.e. the vent will stop closing if the button is released. If there is no trap hazard from a closing vent, Switch 1 can be set, which will fully close the vent without the need to keep the button held.

If parameter bit of [ZARA] is set (default), the vent will fully automatically auto-close when the input is cleared. If the [ZARA] bit is cleared then a short press on the MCP reset button is needed to start the auto-close.

#### **Switch 2 No Actuator – Default position = off**

Setting this switch will disable actuator drive for this MCP. The MCP S DFA input and buttons will still operate other MCPs set to the same zone.

#### **Switch 3 No Smoke – Default position = off**

The smoke detector/fire alarm (S DFA) input is disabled and ignored.

#### **Switch 4 Top of Stack – Default position = off**

This switch is set for “top of stack” and stairwells and will activate the MCP if any other vent in the smoke shaft is open.

The top-of-stack zone will remain open until all other vents are fully closed. If there are no fingertrap risks, the Auto reset

### 3.19. Top/Bottom of Stairwell

To operate as a stairwell, the MCP must have the ‘Top of Stack’ switch set. If no finger trap hazard exists, the auto dipswitch may be set to close the vent automatically on stack reset.

From software 1.1 onward, zone 15 is pre-configured to be “Top of Stairwell”. An MCP set to TOS in zone 15 will by default have special properties:

Support independent zones, which activate the stairwell but not top of stack – see parameter [ZXST] Support of shared stairwell from multiple coordinators.

It is common to have an MCP at the bottom of a stairwell providing dual controls to the top of stairwell. It is possible to wire a smoke detector/fire alarm input to bottom of stairwell. The bottom of stairwell should be set to the same zone as the top of stairwell and have the same TOS and Auto dipswitches.

Bottom of stairwell usually have ‘No Smoke’ and ‘No Actuator’ dipswitches set.

### 3.20. Fitting the MCPs

Ensure both battery and mains power is turned off at the coordinator before plugging the MCP to its connection board.

Ensure the MCP PCB is the correct type – OSLoop MCP circuit boards are coloured black.

Before fitting each MCP, check that the 'NO-MCP' jumper on the connection board is not in the enable (right) position. Check the motor type jumper on the connection board is correct.

Take great care setting the zone address switch and the dipswitches match the required settings. If used, ensure both top and bottom of stairwell MCPs have the top-of-stack dipswitch set.

Check that none of the 24 pins on the MCP are bent or damaged before plugging the MCP onto the connection board.

**Note:** Plugging and unplugging MCPs onto a powered up OSLoop system will very likely result in permanent damage to the MCP.

### 3.21. Operation of the MCP Cover Flap

If the cover flap has been lifted, it cannot be closed unless a reset key is inserted in the slot on the underside of the MCP. Never insert a screwdriver or other objects into the reset key slot.

Take care in opening the cover flap if the underside screws have not been secured.

### 3.22. Mains Power Supply

**Note:** Mains electrical installation must be carried out by a certified competent person, and in compliance with current IEE wiring regulations

The mains power is wired from a local fused outlet (or preferably a fused double poll isolating key switch) to the live, neutral and earth terminals of the supply using FP Plus or flexible three core cable. If using FP Plus, the earth connection should be sleeved green/yellow. Ensure the supply is protected by a 5 amp fuse or breaker.

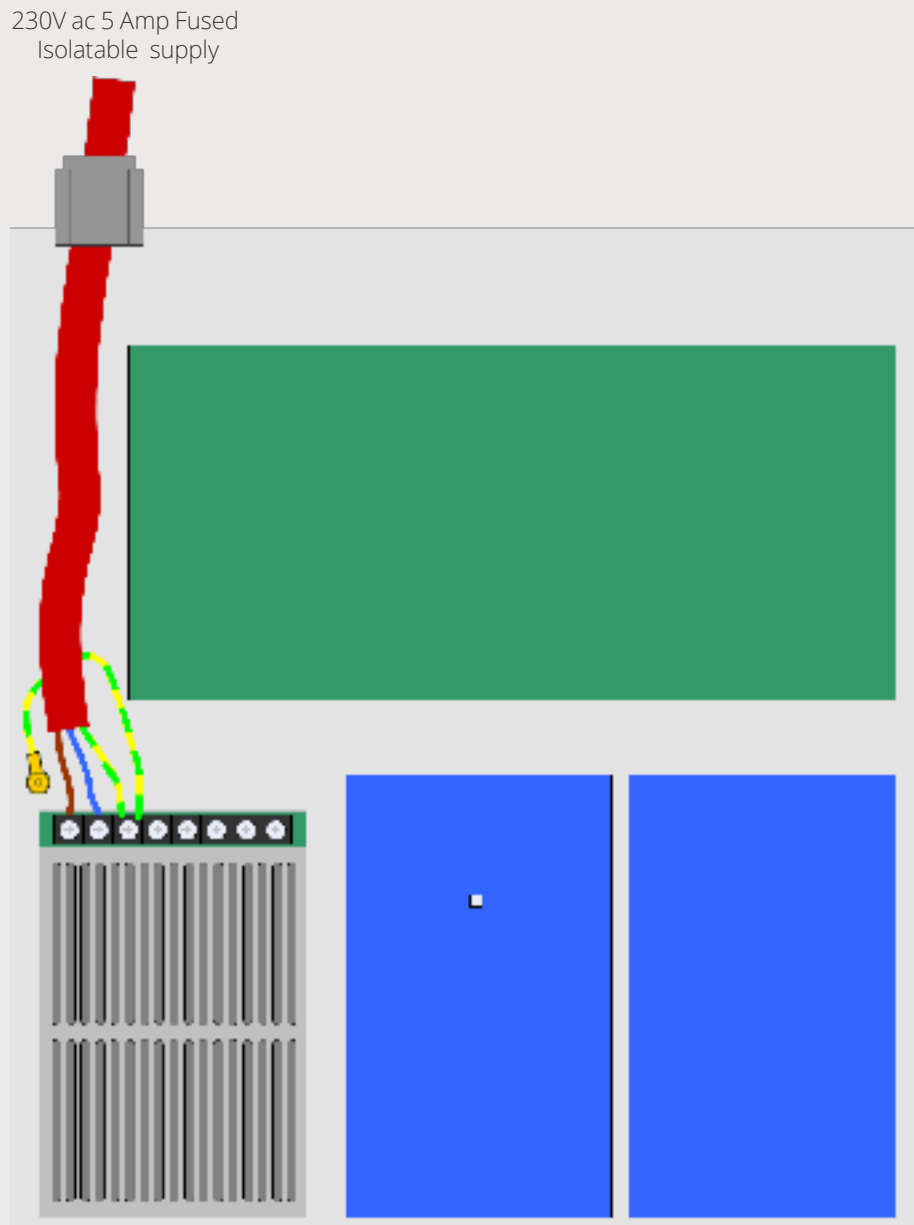

The power supply earth terminal also connects to the chassis - ensure this earth connection is properly made.

## 4. Fault Codes

**Note:** The fault flash codes at the coordinator and at the MCP are different, and have different meanings. Ensure that you are referring to the correct fault guide

### 4.1. Coordinator Flash Codes

Flashes	Fault	Action
1	Service Due	The service interval is due. The service interval warning may be cleared by a Level 2 Reset Key, or parameter reset by Sceptre.
2	Comms Fault	An OSLoop communications link is broken, and the system cannot communicate with some devices. Check leds on all MCPs. Lamptest all MCPs. Check wiring. Replace MCP if faulty.
3	VA Fault	Check the incoming mains supply.
4	VB Fault	Check the connections to the battery. Check the battery voltage, if low, allow the battery to charge.  If necessary, replace the batteries.
5	Battery Fault	Check the battery voltage
6	Charger Fault	Check the connections to the battery. Check the battery voltage, if low, allow the battery to charge.  If necessary, replace the batteries.
7	MCP Fault	Check each MCP on this coordinator. Any MCPs showing flashing yellow led should be investigated. See MCP fault codes below.
8	MCP Switches	MCPs have inconsistent switch settings - check all MCP top of stack and zone switches.
9	VB Loaded	An MCP is drawing current from the VB supply, preventing battery charging. Check the VA supply ~25.5V. Disconnect the battery and look for non-functioning MCPs.
10	VB Fused Trip	The VB power line has drawn excessive current. - Check wiring, and isolate VB to find fault.
11	Incompatible	MCPs and Coordinator have incompatible software - update software on coordinator or MCPs. - Pressing the INST button (top centre of Coordinator PCB) can start the MCP update which takes approximately 2 minutes.
12	System Fault	The parameter set is corrupt or some other critical fault has occurred. Report to SEC technical. Removing all power and restoring may cure the problem.
13	OSLink Fault	Multi - coordinator systems only.  The OSLink connection to other coordinators or repeater panels has a problem. Check all devices have a unique OSLink addresses [OADD], and other configuration parameters. Check OSLink wiring.
14	Remote coordinator faulty	Multi - coordinator systems only. Another coordinator (connected via OSLink) has a fault.

## 4.1. Coordinator Flash Codes (continued)

Flashes	Fault	Action
15	Comms Warning	An OSLoop communications link is broken, but the system can still communicate with all devices. The two MCPs either side of the break should be flashing yellow.
16	Unused/Reserved	

**Note:** The coordinator will flash the front panel yellow led to indicate the cause of the coordinator fault. If more than one fault is present, the fault codes are blinked out in sequence with a pause between each one.

## 4.2. MCP Flash Codes

If the green and yellow LED on the MCP are both constantly lit, then the system is indicating service due. This indication can only be reset by an engineer.

If the yellow LED on the MCP is constantly lit (i.e. not flashing) then the fault is elsewhere on the system.

The MCP will constantly flash the front panel yellow led to indicate a local fault. To discover the fault code, the silence button (MCP underside, left hand side) must be briefly depressed, and the number of yellow flashes counted. If more than one fault is present, the fault codes are blinked out in sequence with a pause between each one.

Flashes	Fault	Action
1	Service Interval Due.	Service interval due.
2	Smoke Detector Open Circuit	Check wiring to the smoke detector and presence of the end of line terminating resistor.
3	VA Fault	Check the incoming mains supply at the coordinator.
4	Motor Open Circuit	Check the connections to the actuator, and presence of the end of line terminating resistor.
5	Motor Short Circuit	Very high current drawn by actuator. Check the wiring for short circuits. If possible, test the actuator from a separate supply, otherwise replace the actuator.
6	Motor Current	Excessive current drawn by actuator. Check the vent is not mechanically obstructed. If possible, test the actuator from a separate supply, otherwise replace the actuator.
7	Motor Limit Switch	The vent motor position has not been proved open or close. Press the reset button until the vent is closed.
8	Smoke Detector Short	The smoke detector input is taking excessive current. Check smoke detector wiring for short circuits.
9	Comms Fault	This MCP is receiving bad data. Check wiring. Check NoMCP jumper on connection board. If system wide, check coordinator.
10	Comms Timeout	This MCP is receiving no data. Check wiring. Check NoMCP jumper on connection board. If system wide, check coordinator.

## 4.2. MCP Flash Codes (continued)

Flashes	Fault	Action
11	VA Fault	An OSLoop communications link is broken, but the system can still communicate with all devices. The two MCPs either side of the break should be flashing yellow.
12	VB Fault	This MCP has lost its VB power supply.
13	Active Overdue	<p><b>Note:</b> indication of this fault is delayed for an hour to allow use of the system in a fire without raising fault conditions.</p> <p>The vent has been closed, but the smoke detector input is not clear. Clear any smoke or reset the fire alarm, then press reset to clear the smoke detector. If faulty, replace the smoke detector head.</p> <p>Also top of stack or stairwell was manually closed while the smoke stack remains active. Close all smoke stack vents.</p>
14	Magcatch Dropout	<p>Mains power was lost, and the battery voltage dropped too low to support the magnetic catches.</p> <p>Restore the mains supply and reset the vents.</p>
15	Coordinator Fault	Check the coordinator fault indication – Refer to coord flashcode in section 4.1.
16	Fan Fault	The fan or fan proving system has failed.



Creating a healthier & safer environment

Lancaster House  
Wellington Crescent  
Fradley Park, Lichfield  
Staffordshire WS13 8RZ

**+44 (0)1543 443060**  
**sales@secontrols.com**  
**www.secontrols.com**

